

	Page
Fuseology	1
Mini Blade Fuses	2
Mini Circuit Breakers	3
Vehicle Electrical Center	4
ATC Blade Fuses	6
ATC Circuit Breakers	7
Series 15600	
ATC® Blade-Type Fuse Panels	8
In-Line Fuseholders	
In-Line Fuseholders for Blade-Type Fuses	9
MAXI Blade Fuses	10
MAXI Circuit Breakers	11
Series 180 HI-AMP	
Auto, Manual & Switchable Reset Circuit Protectors	12
Series 174 FLAT-PAK	
Manual Reset Circuit Protectors	13
Series 120 SHORTSTOP	
Auto, Manual & Modified Reset Circuit Protectors	14
ABI	15
Fusible Links	15
Stud Type Junction Blocks	16
Stud Type Junction Blocks (Non-Feed-Thru)	17
Glass Fuses	18
Series S8 Glass Fuseholders	19
Series 15968	
Battery Disconnect Switch	20
Shunts	21
Specialty Units	21
Cross Reference	22

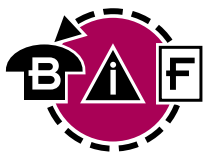

Bussmann
Information Fax ~
414.527.1450

Get the latest, most up-to-date specification data on products listed in this catalog by calling **Bussmann Information FAX**.

BIF is a simple to use automated fax response system. No need to wait for normal business hours, BIF is available around the clock for your convenience. All you need is a touch-tone telephone and a fax machine to get specification data when you want it.

A **BIF** document number is indicated with each product in this catalog. To get a detailed specification sheet simply call 314-527-1450 and follow the prompts. In a matter of minutes, a data sheet will be faxed to you. It's that simple!

© 1995 Cooper Industries, Bussmann Division
 Printed in U.S.A.

This catalog is intended to present product data and provide technical information that will help the end user with design application. Bussmann reserves the right, without notice, to change design or construction of any products and to discontinue or limit distribution of any products. Bussmann also reserves the right to change or update, without notice, any technical information contained in this catalog. Once a product has been selected, it should be tested by the user in all possible applications.

Bussmann®

Automotive OEM Circuit Protection



COOPER
Bussmann

Overcurrent devices provide two main purposes in an electrical circuit:

1. To protect components, equipment, and associated wiring from costly damage.
2. To isolate sub-systems from the main system once a current fault has occurred.

Fuses and circuit breakers are commonly selected as the preferred overcurrent device.

Fuses

The key component of a fuse is the “element”, a short piece of metallic wire or strap made of a material with a relatively low and predictable melting point. Fuses are current sensitive devices and selected to be the weakest link in the circuit. Circuit protection is provided when the fuse link melts and safely interrupts the overcurrent demand. The key criteria to judge the performance of a fuse is the time versus current characteristic curve. This curve can be used to match the fuse with the anticipated overcurrent load expected in the application.

Thermal Circuit Breakers

The basic components of a thermal circuit breaker are the composite alloy reed, two precious metal contacts, and the interconnecting terminals. When an overcurrent occurs, heat is generated as the current flows through the reed causing the reed to deflect and snap open. This separates the contacts and safely interrupts the current flow. Two important parameters used to judge the performance of thermal circuit breakers are the time versus current characteristic curve, similar to the fuse, along with the speed at which the contacts snap open. The relative speed at which the contacts separate is a measure of the cycle life under electrical loading demands. Bussmann Automotive Technologies carefully designs its snap acting reed element to insure long cycle performance for its products.

TYPES OF OVERCURRENT

Any current that exceeds the ampere rating of the fuse or circuit breaker should be considered an overcurrent. Overcurrent situations are generally classified as either a short circuit or an overload condition.

Short Circuit

Short circuit is a current condition that greatly exceeds the rating of the device. It is caused when a malfunction or accident creates a break in the normal path allowing electricity to flow directly to ground. This shorter current and path bypasses the resistance offered by the circuit components connected in the normal current path. In this situation there is virtually no resistance to impede the current and the current will build to a level where the heat generated can cause insulation and/or equipment breakdown.

Overload

An overload is an overcurrent that is within the normal current path. Overloads occur when the current exceeds the value for which the equipment or associated wiring is rated. This typically occurs when too many devices are connected to the circuit or when a device connected to the circuit malfunctions. Sustained overloads may slowly cause overheating of the wiring and the components. The circuit protection device must open before these types of overloads cause damage.

SELECTING OVERCURRENT PROTECTION

During normal conditions, an overcurrent protection device must carry the current without nuisance openings. However, when an overload or short circuit occurs the device must interrupt the overcurrent and withstand the voltage across the device after arcing. To properly select an overcurrent device the following items must be carefully considered:

- **Voltage rating:** represents the maximum system voltage present in the circuit in which the overcurrent device is installed. The system voltage should not exceed this value for proper operation of the device during an overcurrent event.

- **Current rating:**

This is the amperage value marked on the circuit protection device. The circuit protection device is designed to handle this value under steady operating conditions and at ambient temperatures near 25°C. Since field applications often deliver loading conditions and ambient temperatures that vary from ideal nominal settings, it is recommended that circuit designers select device ratings above the nominal circuit current to prevent nuisance trips.

- **Characteristics of equipment to be protected/In-rush characteristics:**

During the operation of protected equipment, system current can significantly vary. This is particularly evident when motor or other inductive loads in the circuit cause large current surges during start-up or shut-down. Circuit protection designers should be aware of these surges and/or in-rush characteristics and select the overcurrent protection device to either accept or reject these current fluctuations as desired.

- **Available short circuit current:**

During a fault or short circuit condition the fuse or circuit breaker may receive a burst of current due to an unleash of available supply current into the circuit. Large DC battery supplies and high current rated electric distribution buses often have this potential for severe short circuits. In these situations the current protection device should be rated to safely clear these instantaneous peak current possibilities.

- **Ambient conditions:**

The time it takes to interrupt the current is dependent upon the ambient current temperature characteristics. Ambient temperature refers to the temperature of the air immediately surrounding the circuit protection device. The effective fuse or circuit breaker ambient temperature to be considered can be appreciably different than the outside room or larger enclosure containing the device. This can occur when the device is contained in a tight area or it is mounted in or near a heat producing component such as a transformer or resistor. When selecting a fuse or circuit breaker at ambient temperatures significantly different from the stated nominal temperature, the circuit designer should adjust the selected overcurrent protection rating based on the published derating curves.

Fuses — may be preferred when fast response to a short circuit condition is required or when high available short circuit currents could occur. Fuses are also less sensitive to high ambient temperature conditions. Fuse characteristic curves can be used to carefully size the device to a critical or special application.

Circuit Breakers — may be preferred for mild overload and short circuit faults. They have a clear advantage of resetability. Four different methods for reset are generally available:

- Type I (*automatic reset*): the circuit breaker cycles continuously during an overload condition until the overload is removed or corrected.
- Type II (*modified reset*): the circuit breaker contains an additional resistive component that causes the device to remain open as long as power is available or the overload is removed.
- Type III (*manual reset*): the circuit breaker contains a trip indicator button or lever that must be manually activated to return the device to normal operation.
- Type III (*switchable*): same as the manual Type III with the option of allowing the user to disable the circuit using an external trip button.

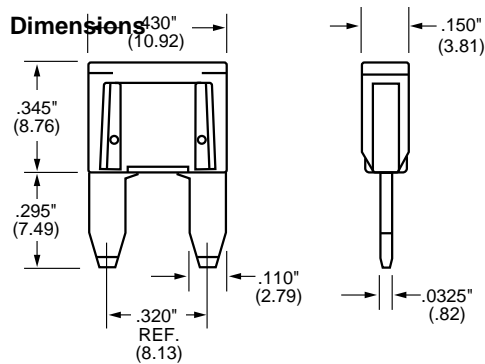
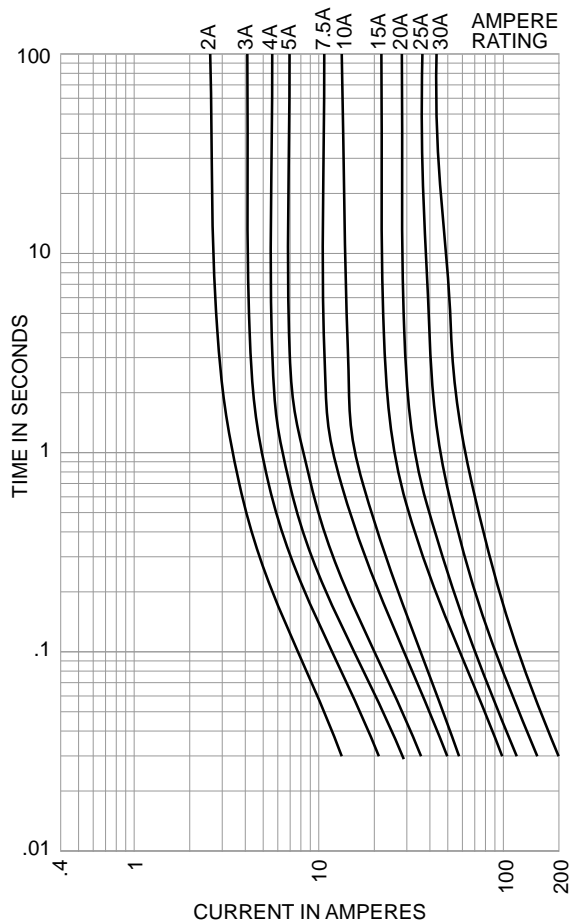

ATM Mini® – Fuse

Fast Acting

SPECIFICATIONS

Voltage Rating: 32V

Agency Approvals: UL Recognized (3-30A)

Guide JFHR2, File E56412

Part No.	Amp Rating	Color
ATM-2	2	Gray
ATM-3	3	Violet
ATM-4	4	Pink
ATM-5	5	Tan
ATM-7.5	7.5	Brown
ATM-10	10	Red
ATM-15	15	Lt. Blue
ATM-20	20	Yellow
ATM-25	25	Natural
ATM-30	30	Green



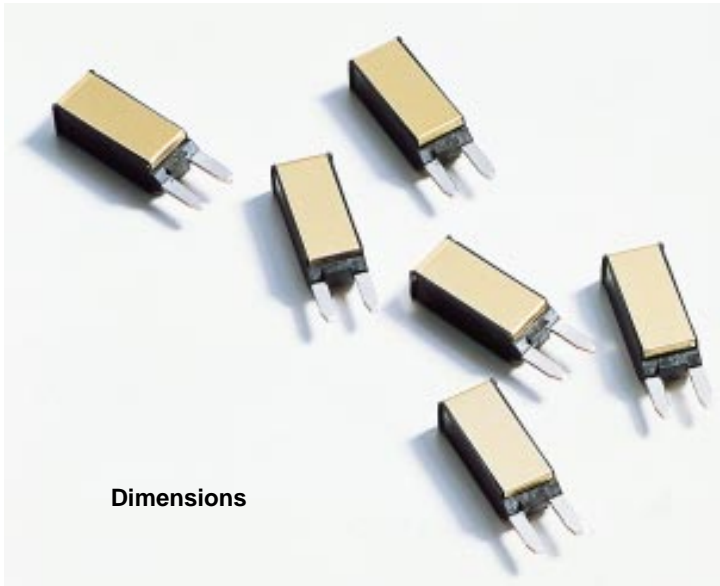

Dimensions

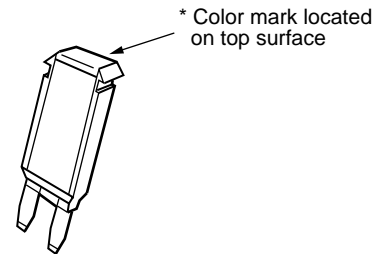
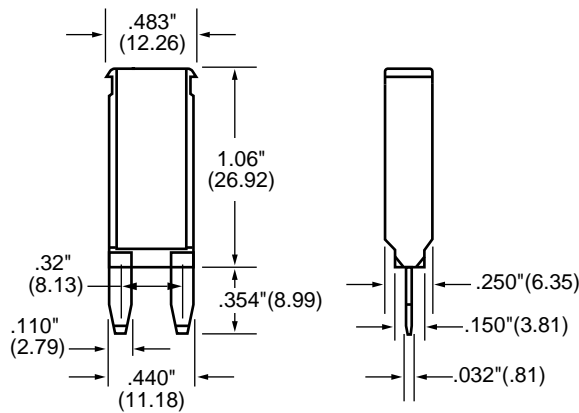

Series 210 Mini

Auto & Modified Reset Circuit Protectors

SPECIFICATIONS

Single Pole Thermal Type Breakers

Ratings: 10A, 15A, 20A, 25A; Voltage of 14VDC.

Operating Temperature: -40°F (-40°C) to 185°F (85°C).

Storage Temperature: -40°F (-40°C) to 260°F (125°C).

Cover: Gray plastic housing with standard gold cover (Type I) or silver cover (Type II).

Marking: Standard marking includes amp/volt ratings, part number, and date code.

Termination Type: Compatible with 280 Type fuse blocks using 8.1mm centerline.

Approvals: Complies with SAE standard J553 Type I and Type II Circuit Breakers.

PART NUMBERING SYSTEM

Series



211 – Type I, 14VDC
212 – Type II, 14VDC

Rating*



10 – 10 amps (Red)
15 – 15 amps (Blue)
20 – 20 amps (Yellow)
25 – 25 amps (White)

Marking



00 – Std. Marking
(Consult Factory for Special Options)

Special Options



(Consult Factory for Special Options)



VEC - 280

The VEC 280 product is an electrical distribution panel for DC powered vehicles. The panel is capable of accepting plug-in type automotive components such as fuses, relays and circuit breakers. Together with the customizing capability of the panel's internal power circuit layers, it can accommodate the circuit protection, relay, and wire management needs for the entire vehicle electrical system.

The panel is designed to accept standard components having 2.8mm wide blade terminals on 8.1mm centerline spacing. These dimensions match many commonly available devices (Mini fuses, relays, circuit breakers) which may be installed as plug-in components in the 64 termination points on the top.

The internal design consists of multi-layer metal grids, each of which can be readily customized to accommodate a wide range of circuit options. Layer spacing is designed to allow for direct plug-in of input and output connectors on any of three sides of the panel. One or two input connectors can be provided having up to 3 inputs per connector. Up to 4 (8 position) output connectors can be selected.

- **Reduce**
 - **Tooling Costs & Lead Times**
 - **Number of External Splices.**
 - **Need for jumper wires.**
- **Allows for internal bussing to relays.**
- **Low Profile Mounting.**

SPECIFICATIONS

Electrical Ratings, Amperage:

Input Capacity For All Circuits: 200 amps maximum

Input Terminal Rating: accepts industry standard 8.0 mm blade terminals; 70 amps per terminal max.

Output Terminal Rating: accepts industry standard 2.8mm blade terminals; 30 amps power terminal max.

Top Level Plug-in Components: 30 amps max. device rating. Each circuit panel to withstand electrical overload of 135% on any Mini Buss® fuse or Buss compatible circuit breaker device without evidence of damage or distortion.

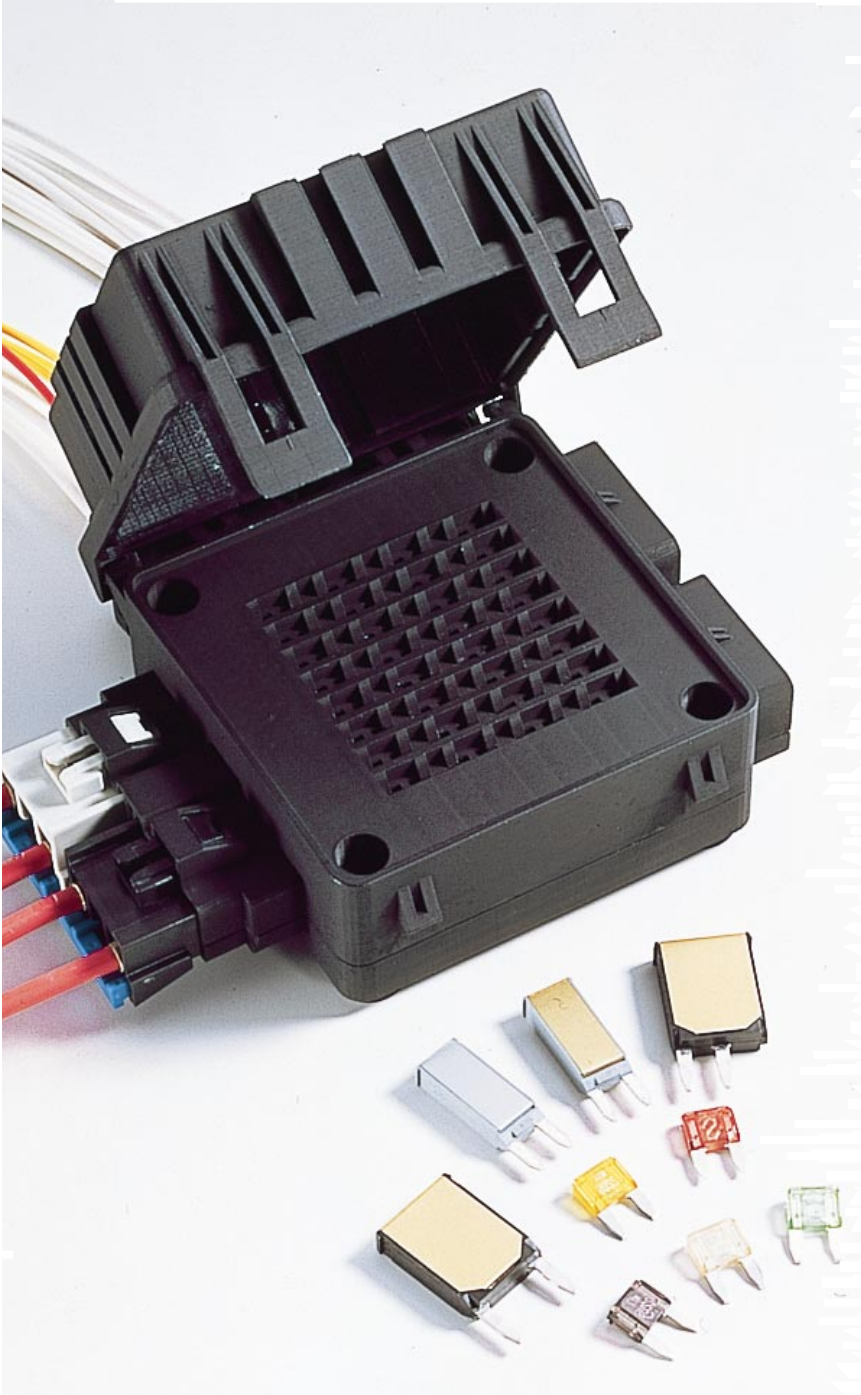

Dimensions

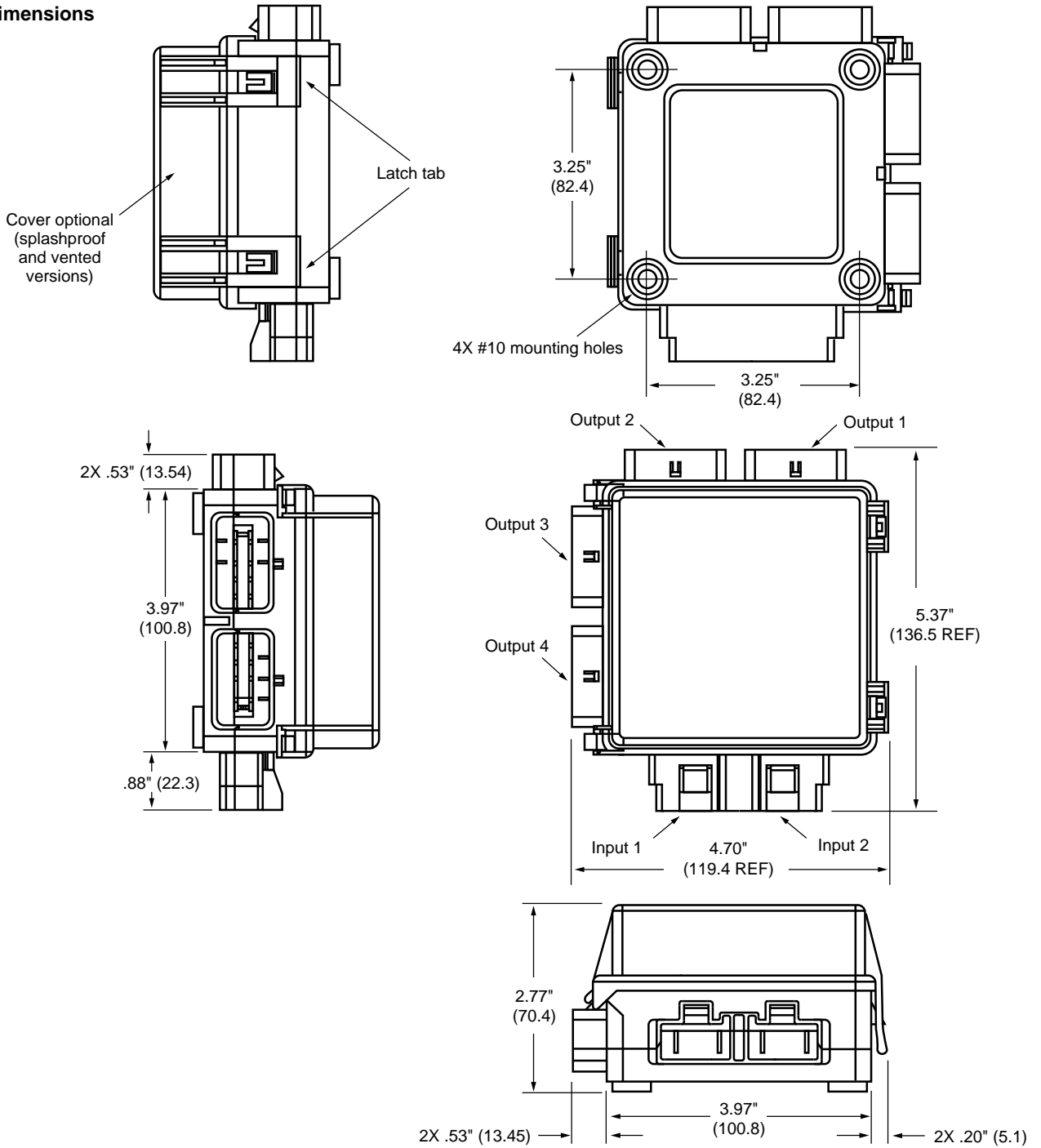

PART NUMBERING SYSTEM

Series

VEC

VEC

280

280

Style

□

1 – Single Module
2 – Double Module

Cover

□

0 – Standard (No Cover)
1 – Splashproof
2 – Vented

□□□

Custom Number



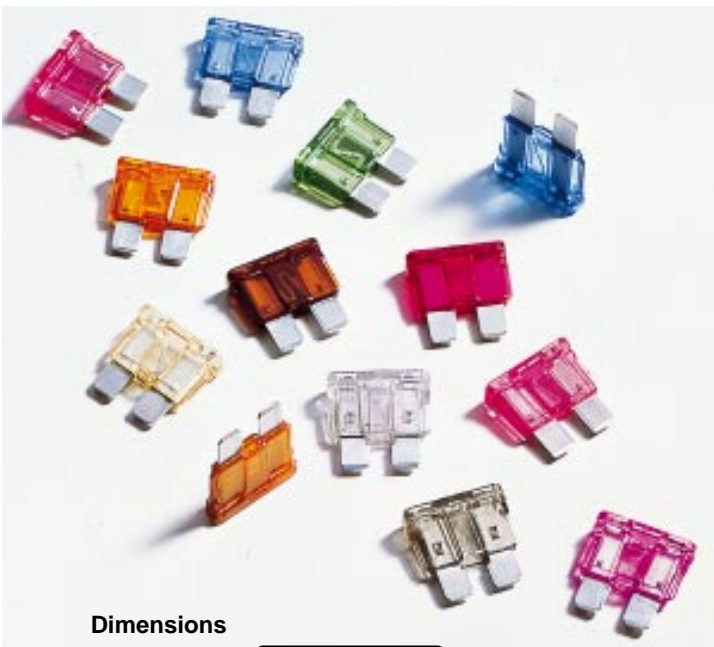

Dimensions

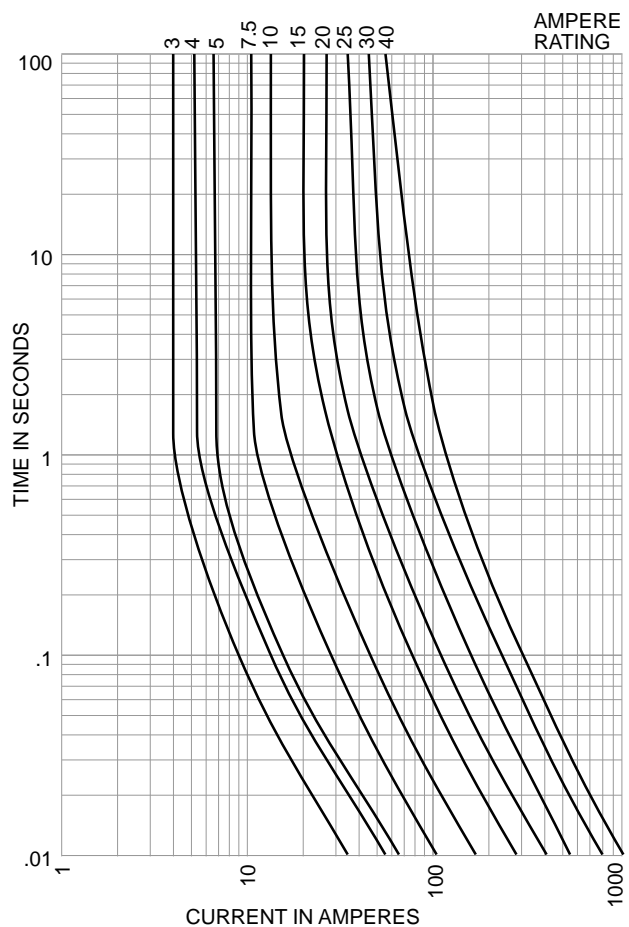
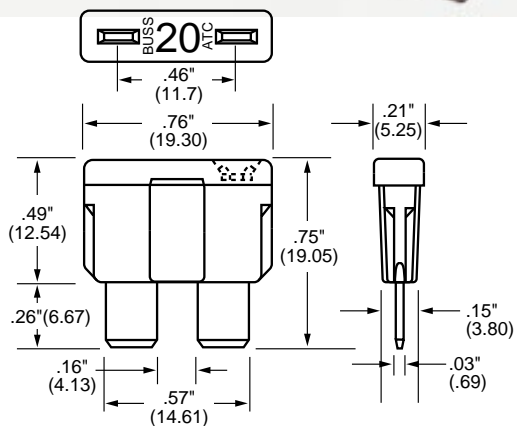

ATC® Blade – Type Fuse

Fast Acting

SPECIFICATIONS

Voltage Rating: 36V

Agency Approvals: UL Recognized, (3-40A)
(Guide JFHR2, File E56412)

Part No.	Amp Rating	Color
ATC-1	1	Black
ATC-2	2	Gray
ATC-3	3	Violet
ATC-4	4	Pink
ATC-5	5	Tan
ATC-7.5	7.5	Brown
ATC-10	10	Red
ATC-15	15	Lt. Blue
ATC-20	20	Yellow
ATC-25	25	Clear
ATC-30	30	Green
ATC-40	40	Amber



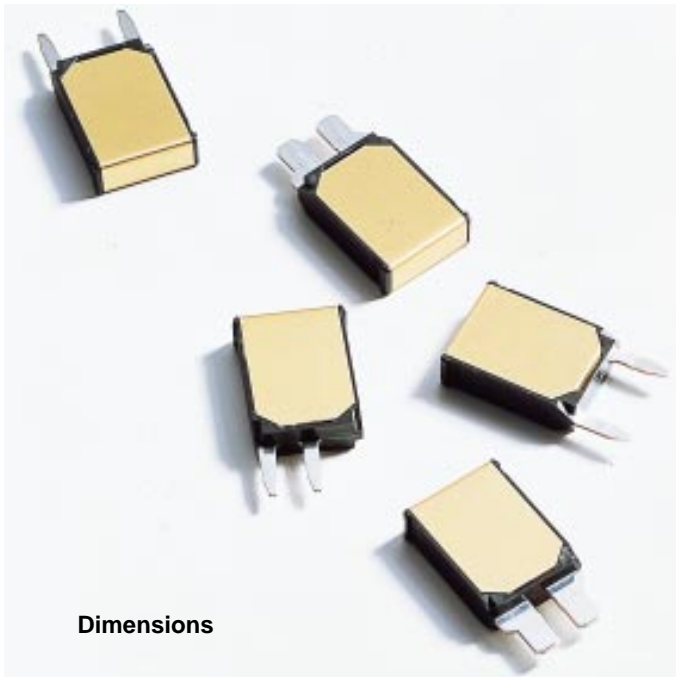

Dimensions

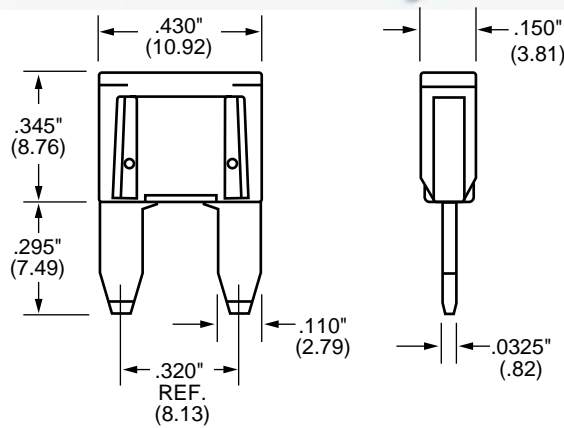

Series 220 ATC®

Auto & Modified Reset Circuit Breakers

SPECIFICATIONS

Single Pole Thermal Type Breakers

- Ratings:** 10A, 15A, 20A, 25A, 30A; Voltage of 14VDC.
- Operating Temperature:** -40°F (-40°C) to 185°F (85°C).
- Storage Temperature:** -40°F (-40°C) to 260°F (125°C).
- Cover:** Gray plastic housing with standard gold cover (Type I) or silver cover (Type II).
- Marking:** Standard marking includes amp/volt ratings, part number, and date code.
- Termination Type:** Compatible with 280 Type or ATC fuse blocks.
- Approvals:** Complies with the requirements of SAE standard J553 Type I and Type II Circuit Breakers.

Terminal Options

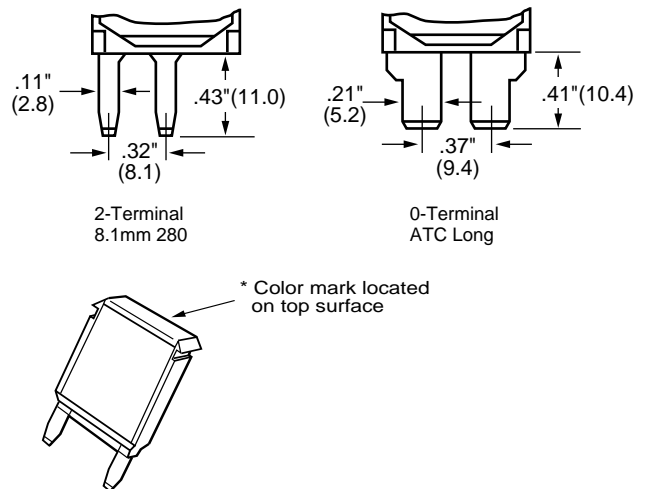

PART NUMBERING SYSTEM

Series



221 – Type I, 14VDC
222 – Type II, 14VDC

Rating*



10 – 10 amps (Red)
15 – 15 amps (Blue)
20 – 20 amps (Yellow)
25 – 25 amps (White)
30 – 30 amps (Green)

Terminal



0 – ATC Long Terminal
1 – 16.2mm 280 Terminal
2 – 8.1mm 280 Terminal

Marking



00 – Std. Marking
(Consult factory for Special Options.)

Special Options



Consult factory for Special Options.



ATC® Blade-Type Fuse Panels

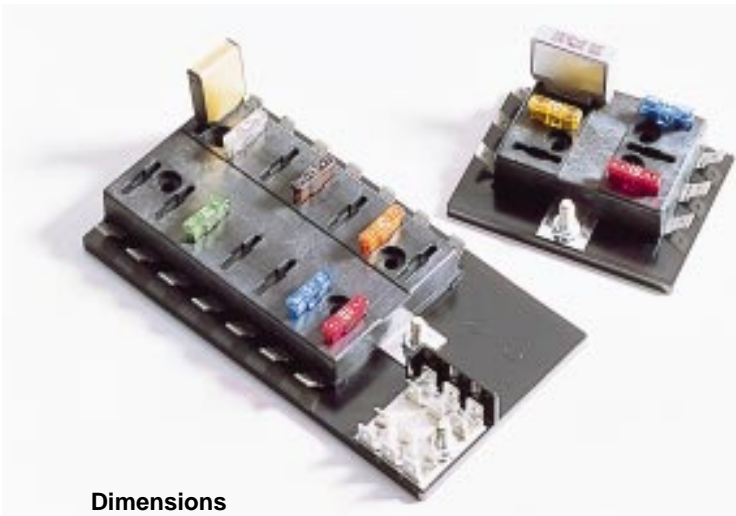

SPECIFICATIONS

Interchangeable Blade Terminals: Accepts ATC® blade-type fuses or circuit breakers.

Wiring: Output terminals - .250" x .032" QC rated 30A max. per circuit; Input terminals - #10-32 stud input rated 150A max.

Positions: Provides 4 to 20 output circuits.

Material: Black, UL rated 94VO thermoplastic, -20°F to 150°F.

Applications: Compact and lightweight, yet rugged enough for use in trucks, buses, boats, RV's, etc.

Other Features: No top cover needed; recessed trifurcated fuse contacts. Recessed mounting holes.

Dimensions

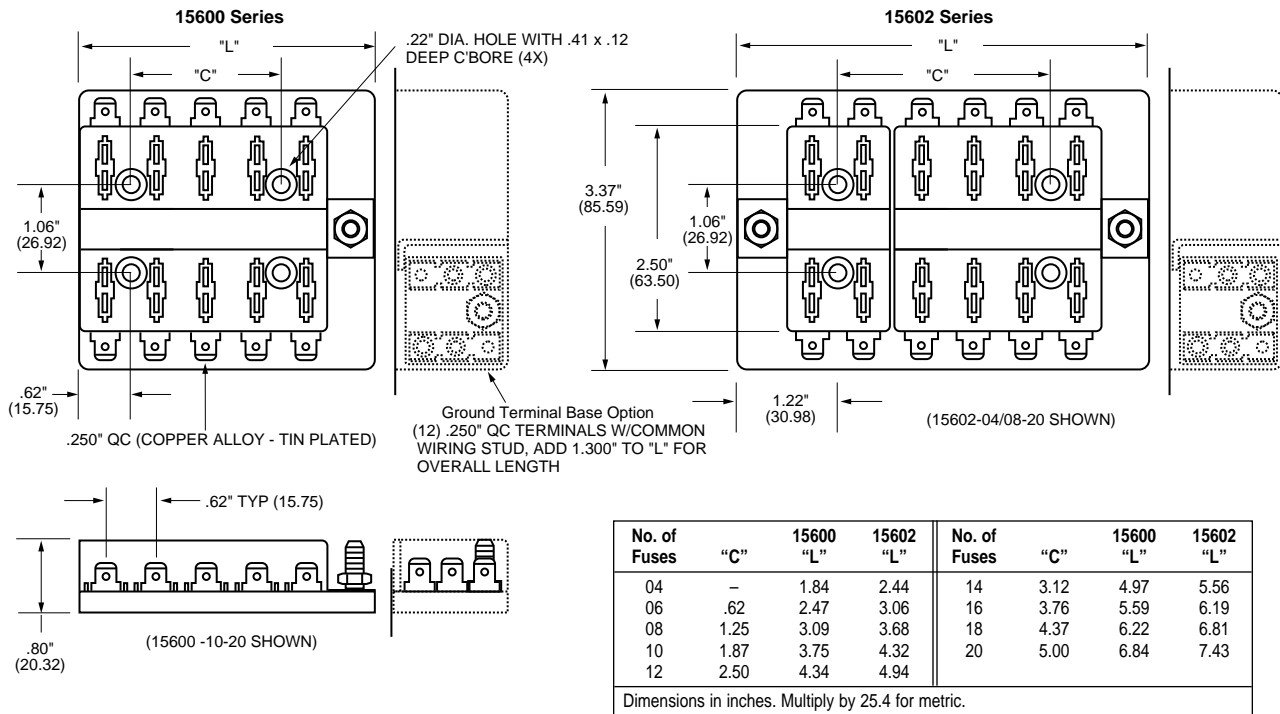

PART NUMBERING SYSTEM

Series	No. of Fuses &/or Circuit Breaker Positions	Hardware Options	Ground Terminal Base
0	—	□	□
1 5 6 0	04-20	□	□
2	□□ / □□	□	□

0 – Single Stud
2 – Double Stud

Left Side 04-16
Right Side 04-16
(max. combination of 20)

0 – W/O nuts
1 – Nuts shipped bulk
2 – Nuts assembled

0 – None
1 – Include Ground Pad

BIF document: 2064



In-Line Fuseholders for Blade-Type Fuses

HHC and HDD

In-Line Fuseholders for ATC® Blade-Type Fuses.

Voltage Rating: 32V, 3-30A.

"Write-in" space for circuit identification on HHC holder. Plastic cover fits both HHC and HDD holders.



BIF document: 2107

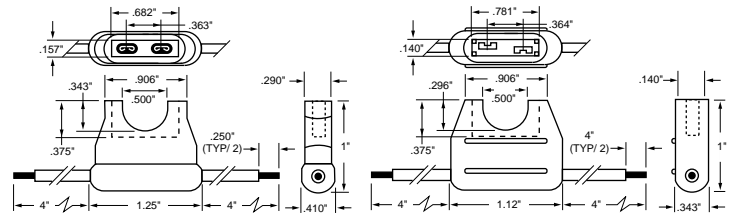

Dimensions in inches. Multiply by 25.4 for metric.

ATC® Blade Type Holder

Catalog No.	Description	Fuse Size	Electrical Connection
HHC	Yellow fuseholder	3-20 amps	#16 lead wire, black wire
HDD	Black fuseholder	3-30 amps	#12 lead wire, yellow wire
HDD-C	Cover only	Fits both HHC & HDD	Clear polycarbonate

*Cover for ATC® Circuit Breaker — consult factory.

HHL and HHM

In-Line Fuseholders for MINI® Fuses.

Voltage Rating: 32V, 30A.

Body material withstands high temps. Protective cover has removable straps.



BIF document: 2128

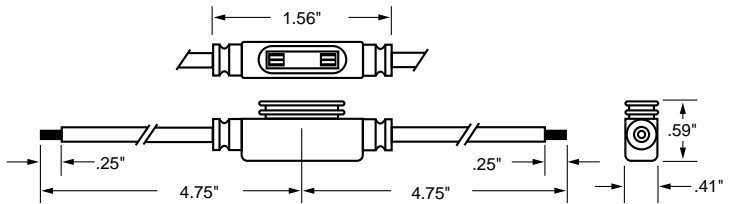

Dimensions in inches. Multiply by 25.4 for metric.

MINI® Fuse Blade Type Holder

Catalog No.	Description	Fuse Size	Electrical Connection
HHL	Fuseholder w/cover	2-20 amps	#16 lead wire; 4" length
HHL-B	Body only		
HHM	Fuseholder w/cover	2-30 amps	#12 lead wire; 4" length
HHM-B	Body only		
HHM-C	Cover only		

*Cover for Mini® Circuit Breaker — consult factory.

HHX

In-Line Fuseholder for MAXI™ Fuses.

Voltage Rating: 32V, 60A.

Firewall mounting hole permits two or more holders to be mounted together. Cover comes with a removable strap.



BIF document: 2129

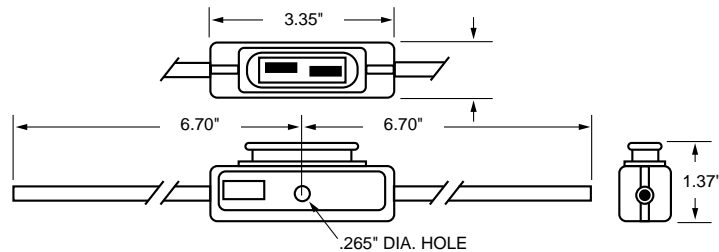

Dimensions in inches. Multiply by 25.4 for metric.

MAXI™ Fuse Blade Type Holder

Catalog No.	Description	Fuse Size	Electrical Connection
HHX	Fuseholder w/cover	20-60 amps	#6 lead wire; 5" length
HHX-B	Body only		
HHX-C	Cover only		



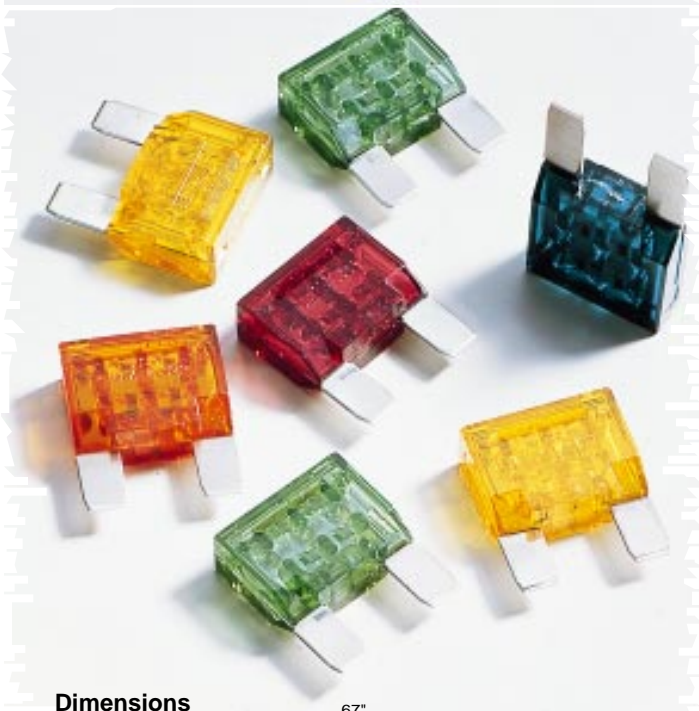

Dimensions

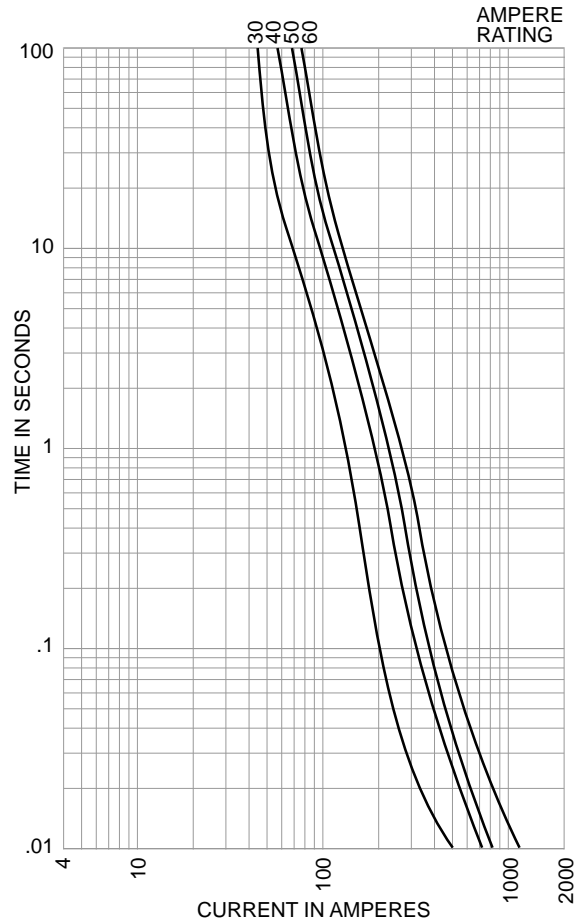
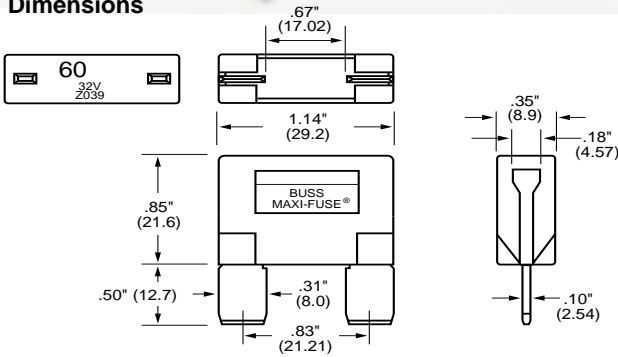

MAX Maxi™ – Fuse
Time Delay

SPECIFICATIONS

Voltage Rating: 32V

Part No.	Amp Rating	Color	Part No.	Amp Rating	Color
MAX-20	20	Yellow	MAX-50	50	Red
MAX-30	30	Green	MAX-60	60	Blue
MAX-40	40	Orange			

BIF document: 2049

Female FMX Maxi™ – Fuse
Time Delay

The FMX is available in ampere ratings from 20 - 80A in both a standard 27 mm height or a shorter 18 mm version for even lower space requirements. Both versions use 5.5 mm blade centers with a 6.0 mm width and .81 mm thick blades.

Part No.	Amp Rating	Color	Part No.	Amp Rating	Color
FMX-20	20	Lt. Blue	FMX-60	60	Yellow
FMX-30	30	Pink	FMX-70	70	Brown
FMX-40	40	Green	FMX-80	80	Black
FMX-50	50	Red			



Dimensions

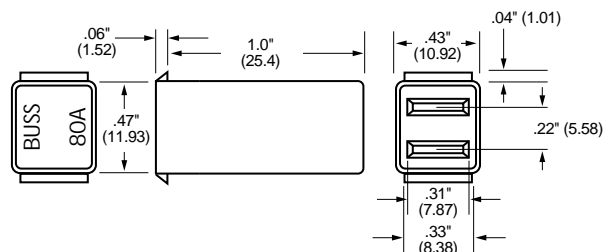

BIF document: 2079



Series 190 MAXI®

Auto, Manual & Modified Reset
Circuit Protectors

SPECIFICATIONS

Single Pole Thermal Type Breakers

Ratings: 8A to 50A; Series 191 & 192
12 VDC; Series 193, 194 & 195 24 VDC.
Operating Temperature: -20°F (-10°C)
to 150°F (65°C).

Storage Temperature: -20°F (-10°C) to
200°F (93°C).

Applications: Trucks, RV's, buses, boats, portable generators, welding equipment, etc.

Interchangeable Blade Terminals: with MAXI® blade fuse.

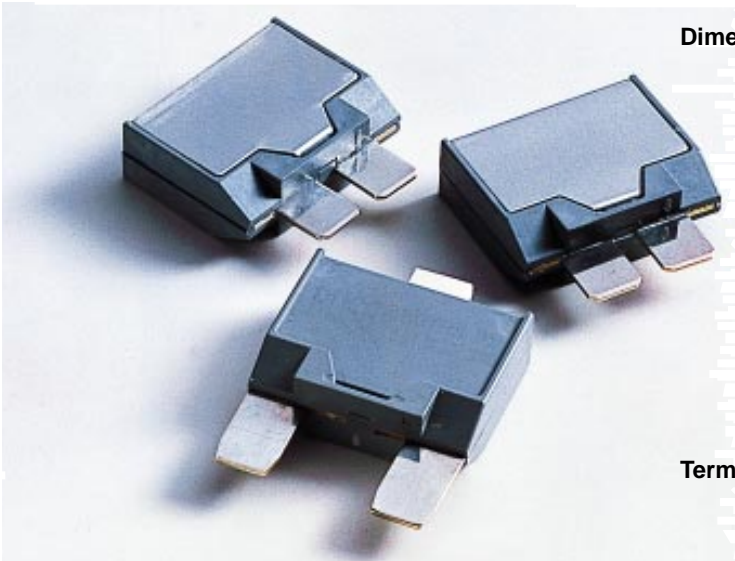
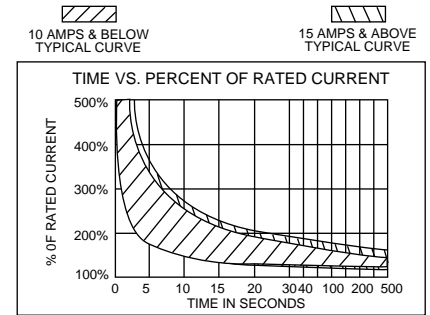
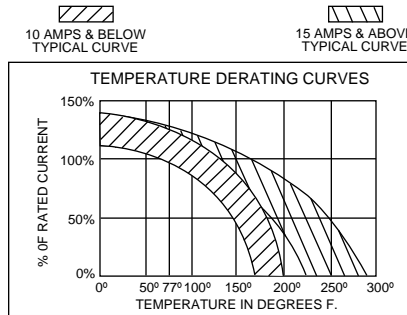

Dimensions

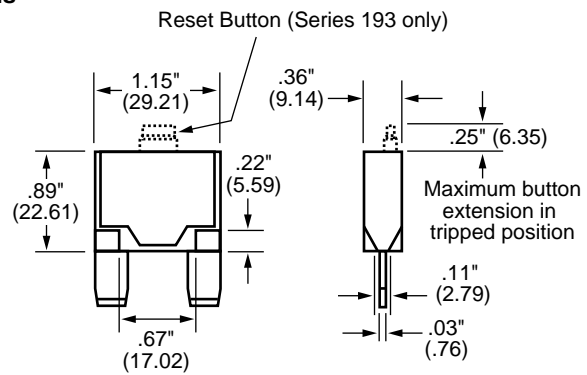

Terminal Options

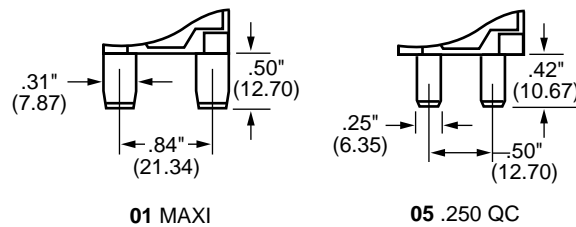

PART NUMBERING SYSTEM

Series	Rating	Terminal	Cover	Button	Marking
1 9		—			
191 – Auto Reset	08 – 8 amps	01 – MAXI	M – Metal*	Blank – No button	Consult factory for special markings.
192 – Modified Reset	10 – 10 amps	05 – .250 Q.C.	P – Plastic	1 – Black	
193 – Manual Reset	15 – 15 amps			2 – White	
194 – Auto Reset	20 – 20 amps				
195 – Modified Reset	25 – 25 amps				
	30 – 30 amps				
	35 – 35 amps**				
	40 – 40 amps**				
	50 – 50 amps**				

* Metal cover aids heat dissipation. Mandatory for Modified Resets. Recommended, but not mandatory on Auto Resets.
** Only available on 01 Terminal.



Auto, Manual & Switchable Reset Circuit Protectors



SPECIFICATIONS

Single Pole Thermal Type Breakers

Ratings: 40A to 150A; 30 VDC.

Operating Temperature: -25°F (-32°C) to 180°F (82°C).

Storage Temperature: -30°F (-34°C) to 300°F (149°C).

Applications: Typically used in auxiliary and accessory circuits -- trucks, buses, RV's and marine applications. Others might include battery chargers and DC audio systems. Series 181, 184 & 185 are sealed for engine compartment and bilge area applications.

Housing: Thermoset plastic; UL rated 94VO; 311°F (155°C). Stud insulators are provided on all covered units.

Mounting: Panel or surface.

Indicator: Series 184 & 185 have a unique reset mechanism which provides visible indication of tripped condition.

Approvals: Complies with SAE Standard J1625

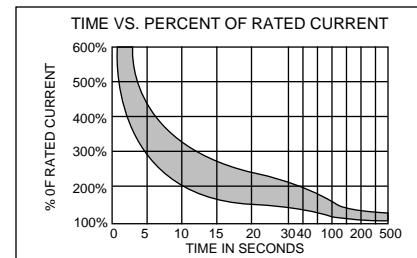
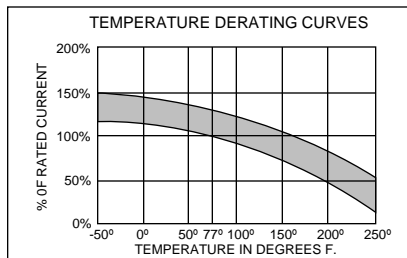

Dimensions

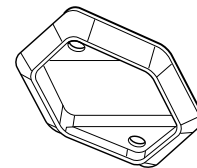
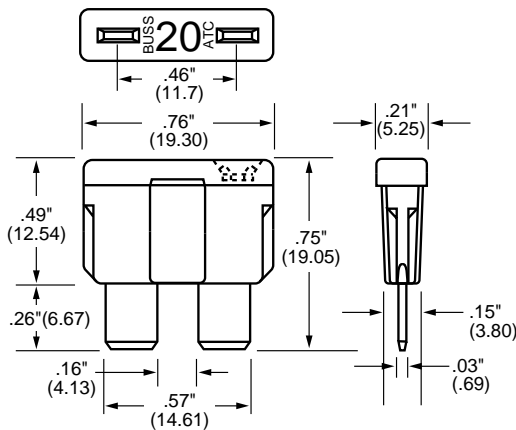

PART NUMBERING SYSTEM

Series



- 181 - Auto Reset
- 183 - Auto Reset
- 184 - Manual Reset
- 185 - Switchable/Manual

Rating



- 040 - 40amps
- 050 - 50 amps
- 060 - 60 amps
- 070 - 70 amps
- 080 - 80 amps
- 090 - 90 amps
- 100 - 100 amps
- 110 - 110 amps
- 120 - 120 amps
- 135 - 135 amps
- 150 - 150 amps

Mounting



- F - Surface Mount
- P - Panel Mount

Terminal Hdwr.



- 00 - Ship w/o nuts
- 01 - Sems nuts installed
- 02 - Sems nuts shipped bulk
- 03 - Stainless Steel Std. nuts & washers installed
- 04 - Stainless Steel Std. nuts & washers shipped bulk
- 05 - Sems nuts - bulk/eyelets installed
- 06 - Sems nuts & eyelets installed
- 07 - Flange gasket & Sems nuts installed
- 08 - Threaded insert & Sems nuts installed

Marking



- 0 - Blank cover
- 1 - Standard Marking; Part Number, Amp Rating
- 181, 184, 185 Series - Top Surface
- 183 Series - Side Surface
- Consult factory for special markings.



Manual Reset Circuit Protectors

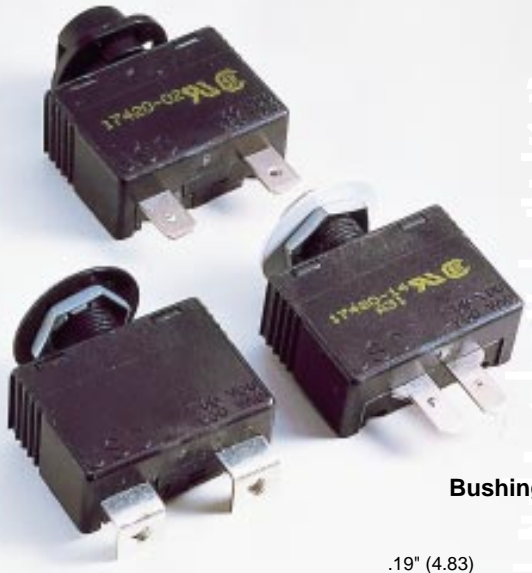

SPECIFICATIONS

Single Pole Thermal Type Breakers

Ratings: 5A to 40A. The derating curves are the same as those for Series 120 which are shown on page 14.

Operating Temperature: -10°F (-23°C) to 150°F (65°C).

Storage Temperature: -20°F (-29°C) to 200°F (93°C).

Applications: Multiple power outlet strips, trucks, RV's, boats, buses, portable generators, building equipment, etc.

Approvals: Series 174 is rated to 250VAC/50DC and meets UL Standard 1077; UL E74569; CSA LR60443; see individual terminal styles for specific rating approvals.

Bushing Options

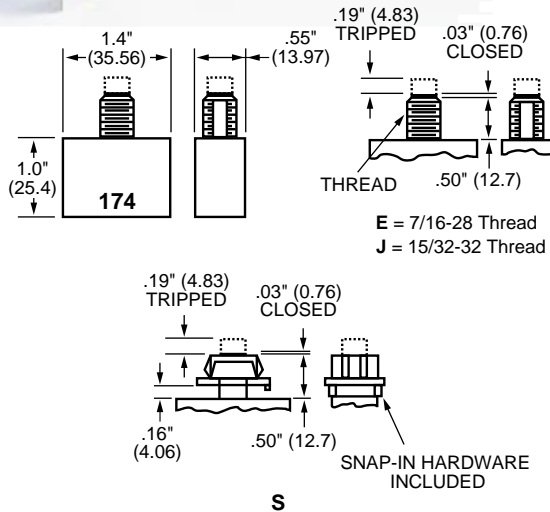

Terminal Options

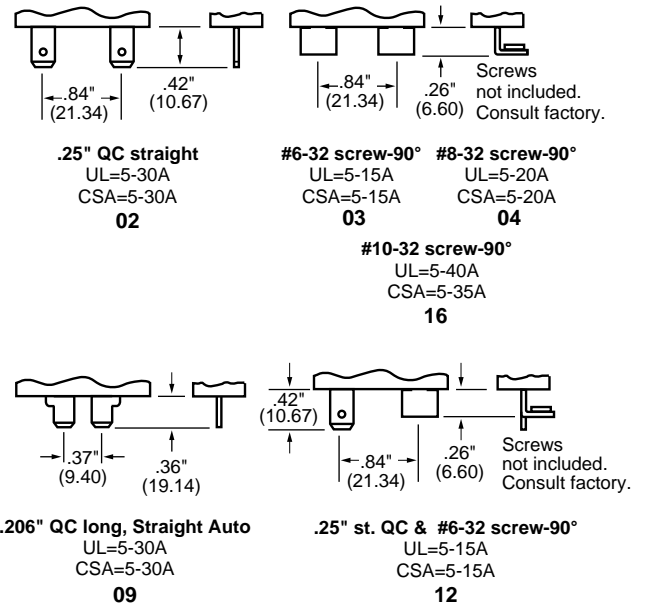

PART NUMBERING SYSTEM

Series	Rating	Housing	Bushing	Terminal	Button	Hdwr. Pkg.	Mounting Hdwr.
174	10	4		02	A	1	A
174 - Type III Manual 250 VAC/50VDC	8 - 8 amps 10 - 10 amps 15 - 15 amps 20 - 20 amps 25 - 25 amps 30 - 30 amps 35 - 35 amps* 40 - 40 amps*	4 - Standard	E - 7/16-28 x .50 molded J - 15/32-32 x .50 molded S - Snap-in bushing	02 - .25" QC straight 03 - #6-32 screw - 90° 04 - #8-32 screw - 90° 09 - .206 QC long, straight auto 12 - .25" QC #6-32 - 90° 16 - #10-32 screw - 90°	A - White w/black rate marking E - White w/red rate marking F - White w/no rate marking L - Black w/no rate marking M - Black w/white rate marking N - Red w/no rate marking P - Red w/black rate marking	1 - Assmbl. to bushing 2 - Bulk 3 - No hardware	A - Knurled nut & palnut B - Knurled nut/palnut push to reset disc (black) C - Knurled nut D - Knurled nut & push to reset disc (black) E - Knurled nut/palnut & push to reset disc (white) F - Knurled nut & push to reset disc (white) G - Snap-in attachment to bushing (required on S bushing) H - Black knurled nut

*Available with terminals 04 or 16 only.



Auto, Manual & Modified Reset Circuit Protectors

SPECIFICATIONS

Single Pole Thermal Type Breakers

Ratings: 8A to 50A; 12 VDC; 24 VDC.

Operating Temperature: -10°F (-23°C) to 150°F (65°C).

Storage Temperature: -20°F (-29°C) to 200°F (93°C).

Applications: Battery chargers, trucks, buses, RV's, trolling motors, etc.

Approvals: Complies with SAE Standard J553.

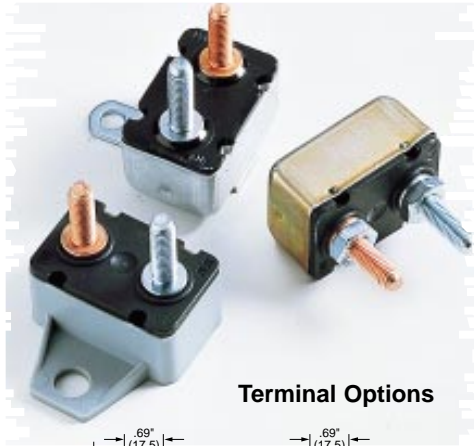

Terminal Options

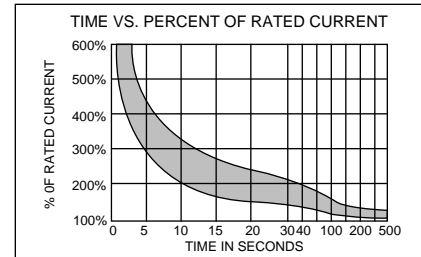
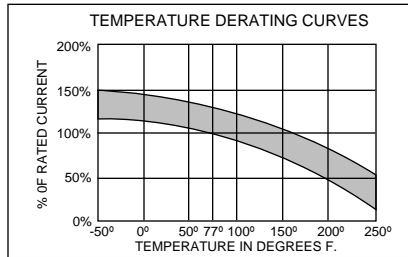
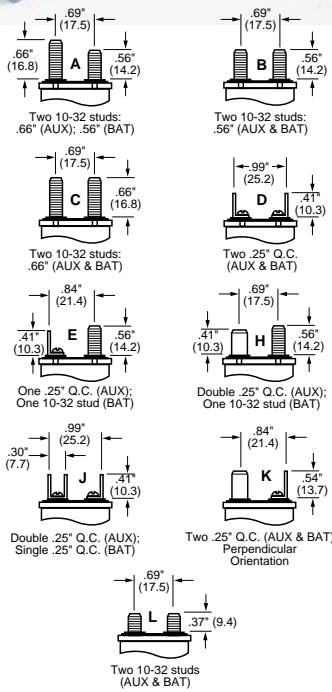

Cover & Bracket Options

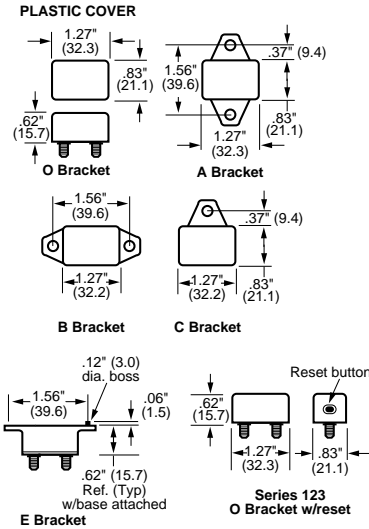
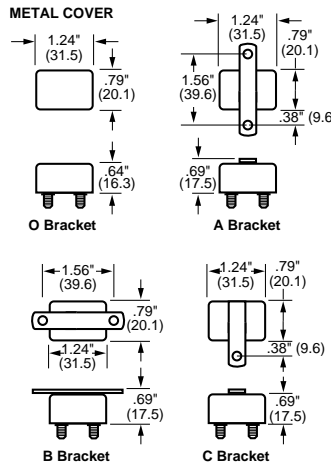

PART NUMBERING SYSTEM

Series	Terminal	Rating	Bracket	Mtg. Holes	Cover*	Options	Hardware
121 - Auto Reset 12 VDC	A - Two 10-32 studs; .66 (Aux), .56 (Bat)	08 - 8 amps 10 - 10 amps	O - No bracket A - Bracket	0 - No bracket 1 - .140 dia.	M - Metal P - Plastic	01 - Waterproof (metal covers only)	WA - Whiz-lock nut assembled
122 - Modified 12 VDC	B - Two 10-32 studs; .56 (Aux & Bat)	12 - 12 amps 15 - 15 amps	B - Bracket C - Bracket	2 - .196 dia. 3 - .237 dia.		02 - Splashproof (optional on metal covers - add 02 suffix; std. on plastic covers - omit 02 suffix.)	WB - Whiz-lock nut bulk unassembled
123 - Manual 24 VDC 115 VAC	C - Two 10-32 studs; .66 (Aux & Bat)	20 - 20 amps 25 - 25 amps 30 - 30 amps	E - Bracket (plastic only)	4 - .265 dia. (plastic only)			HA - Nut & lock washer assembled
124 - Auto 24 VDC	***D - Two .250 QC; (Aux & Bat)	35 - 35 amps 40 - 40 amps		5 - .228 dia. (plastic only)			HB - Nut & lock washer bulk unassembled
125 - Modified 24 VDC	**H - One 10-32 stud .56 (Bat), Double .250 QC (Aux)	50 - 50 amps		6 - .221 dia. (metal only)			KA - Keps lock nut assembled KB - Keps lock nut bulk unassembled
	**J - Single .250 QC (Bat) Double .250 QC (Aux)						
	***K - Two .250 QC (Aux & Bat)						
	L - Two 10-32 studs; .37 (Aux & Bat)						

* Series 123 available in plastic cover only. Series 122 & 125 available in metal cover only.
** 40A maximum
*** 30A maximum



Bolt-in high current, time lag fuse. Ampere ratings from 75 to 200 Amps. IR 1,000A @ 32VDC. Ideal for use in high current heavy-duty applications such as battery and alternator cables.

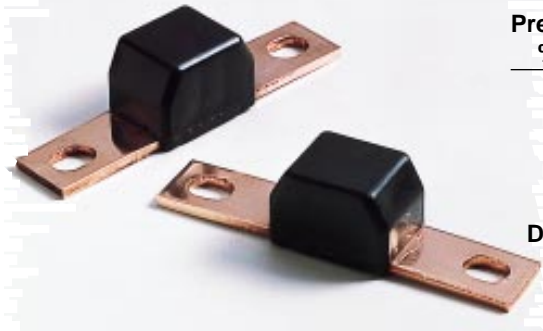

Preliminary blow times:

% Rating	Time (Seconds)
135	1000
200	30
350	5
600	0.06

Dimensions

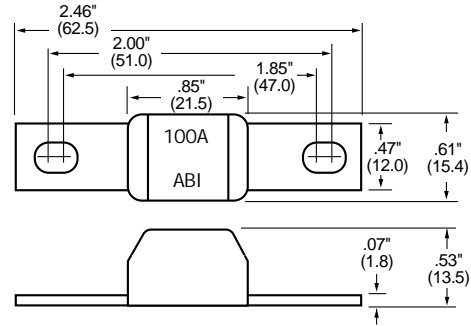

Part No.	Amp Rating
ABI 75	75
ABI 100	100
ABI 125	125
ABI 150	150
ABI 175	175
ABI 200	200

BIF document: 2068

Fusible Links (Protect Wiring Harnesses)



Dimensions

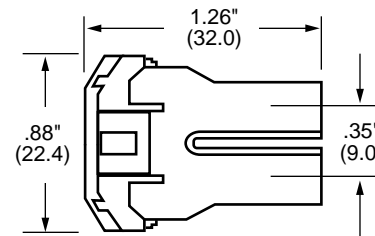

Cat. Symbol	Type Connection	Amperes	Carton Data		Dimensions	Volume
			Qty.	Weight		
FLF	Female	20, 30, 40, 50, 60	10	.30 Lbs.	3"x2"x7 ³ / ₄ "	46.5 cu. in

Part No.	Rated Current	Applicable Wire	Color
FLF-60	60A	AVS 5 (AWG 10)	Yellow
FLF-50	50A	AVS 3 (AGW 12)	Red
FLF-40	40A	AVS 3 (AGW 12)	Green
FLF-30	30A	AVS 2 (AWG 14)	Pink
FLF-20	20A	AVS 1.25 (AWG 16)	Light Blue

Dimensions

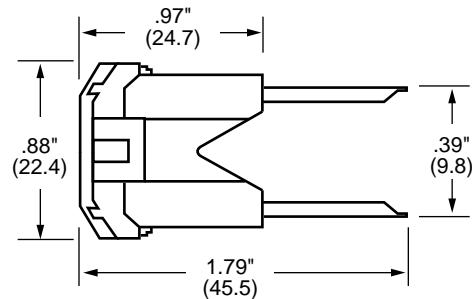

Part No.	Rated Current	Applicable Wire	Color
FLM-120	120A	AV 15 (AWG 6)	White
FLM-100	100A	AV 10 (AWG 8)	Blue
FLM-80	80A	AV 8 (AWG 8)	Black
FLM-60	60A	AVS 5 (AWG 10)	Yellow
FLM-30	30A	AVS 2 (AWG 14)	Pink

Cat. Symbol	Type Connection	Amperes	Carton Data		Dimensions	Volume
			Qty.	Weight		
FLM	Male	30, 60, 80, 100, 120	10	.35 Lbs.	3"x2"x7 ³ / ₄ "	46.5 cu. in

BIF document: 2069



SPECIFICATIONS

Material: Studs on non-feed-thrus are steel plated; feed-thrus are copper alloy.

Applications: Heavy-duty ground or power connection points in AC or DC circuits. Feed-thru or stand alone mount options available for transformers, communication and computer power sections along with various vehicle electrical systems.

Benefits: Modular design offers design and manufacturing flexibility.

Suggested Max. Termination Ratings:

Thread/Stud Sz.	Amperages
#10-32	50 Amps
#1/4-20	100 Amps
#5/16-18	200 Amps
#3/8-16	250 Amps
#1/2-20	400 Amps

Dimensions

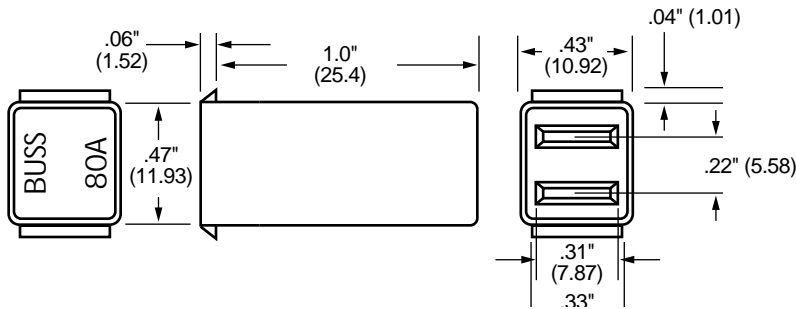

Part	Fig.	A	B	C	D	E	F	G	H	J	K	L	M	Material	Color
C2791*	2	2.06 (52.4)	.69 (17.5)	.44 (11.2)	.62 (15.9)	.69 (17.5)	.31 (7.9)	.69 (17.5)	.06 (1.6)	.06 (1.6)	1.31 (33.3)	.22 dia. w/.41 dia. C'bore x .14 deep	1/4-20	Thermoset	Black
C2909*	2	2.06 (52.4)	.69 (17.5)	.44 (11.2)	.62 (15.9)	1.0 (25.4)	.31 (7.9)	.69 (17.5)	.06 (1.6)	.06 (1.6)	1.31 (33.3)d	.22 dia. w/.41 dia. C'bore x .14 deep	10-32	Thermoset	Black
C2909-1*	2	2.06 (52.4)	.69 (17.5)	.44 (11.2)	.62 (15.9)	1.0 (25.4)	.31 (7.9)	.69 (17.5)	.06 (1.6)	.06 (1.6)	1.31 (33.3)d	.22 dia. w/.41 dia. C'bore x .14 deep	1/4-20	Thermoset	Black
C1938*	2	2.06 (52.4)	.94 (23.8)	.69 (17.5)	.87 (22.2)	.69 (17.5)	.31 (7.9)	.87 (22.2)	.06 (1.6)	.06 (1.6)	1.31 (33.3)d	.22 dia. w/.41 dia. C'bore x .14 deep	3/8-16	Thermoplastic	Black
C1925*	1	2.75 (69.8)	1.5 (38.1)	1.25 (31.7)	1.25 (31.7)	1.12 (28.6)	.37 (9.5)	1.12 (28.6)	.19 (4.8)	.19 (4.8)	2.0 (50.8)	.22 dia. w/.44 dia. C'bore x .16 deep	1/2-13	Thermoplastic	Red
C4044*	2	2.06 (52.4)	.87 (22.2)	.62 (15.9)	.62 (15.9)	1.12 (28.6)	.31 (7.9)	.87 (22.2)	.06 (1.6)	.06 (1.6)	1.31 (33.3)	.22 dia. w/.41 dia. C'bore x .14 deep	3/8-16	Thermoplastic	Black
C5898*	2	2.06 (52.4)	.94 (23.8)	.69 (17.5)	.87 (22.2)	.69 (17.5)	.31 (7.9)	.87 (22.2)	.06 (1.6)	.06 (1.6)	1.31 (33.3)	.22 dia. w/.41 dia. C'bore x .14 deep	3/8-16	Thermoplastic	Red
JB3816-2	2	2.12 (54.0)	1.0 (25.4)	.62 (15.9)	.94 (23.8)	.69 (17.5)	.31 (7.9)	None	.06 (1.6)	None	1.37 (34.9)	.22 dia. w/.37 dia. C'bore x .14 deep	3/8-16	Thermoplastic	Black
JB3816-3	2	2.12 (54.0)	1.0 (25.4)	.62 (15.9)	.94 (23.8)	.69 (17.5)	.31 (7.9)	None	.06 (1.6)	None	1.37 (34.9)	.22 dia. w/.37 dia. C'bore x .14 deep	3/8-16	Thermoplastic	Red
C1933	1	2.75 (69.8)	1.44 (36.6)	1.25 (31.7)	1.5 (38.1)	1.12 (28.6)	.37 (9.5)	None	.19 (4.8)	None	2 (50.8)	.22 dia.	1/2-13	Thermoplastic	Black
C1933-1	1	2.75 (69.8)	1.44 (36.3)	1.25 (31.7)	1.5 (38.1)	1.12 (28.6)	.37 (9.5)	None	.19 (4.8)	None	2 (50.8)	.22 dia.	5/16-18	Thermoplastic	Black
C6344-1	2	2.12 (54.0)	.62 (15.9)	.62 (15.9)	.87 (22.2)	.69 (17.5)	.31 (7.9)	None	.06 (1.6)	None	1.37 (34.9)	.22 dia. w/.37 dia. C'bore x .14 deep	1/2-20	Thermoplastic	Black

*Feed-thru Options – Nuts & washers; consult factory.





BIF document: 2071

Dimensions

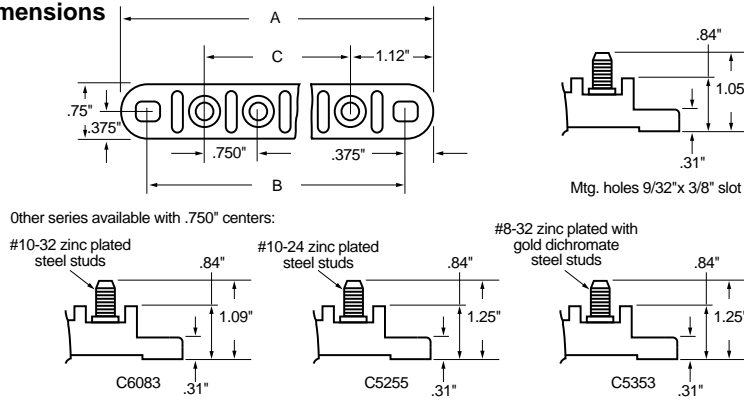

Dimensions in inches. Multiply by 25.4 for metric.

Series C4559

SPECIFICATIONS

Rating: 30A, 600V

Operating Temperature: 250°F (120°C)

Standards: 2 to 16 steel studs on .750" centers and a "dog point" to guide nut onto thread.

Torque: Recommended 20 in/lb (25 in/lb max.).

Marking: Numbers and arrows molded on top of barriers indicate terminals.

Approvals: UL E62622; CSA LR15364.

Part No.	A	B	C
C4559-2	3.00 (76.2)	2.25 (57.1)	0.75 (19.0)
C4559-3	3.75 (95.2)	3.00 (76.2)	1.50 (38.1)
C4559-4	4.50 (114.3)	3.75 (95.2)	2.25 (57.1)
C4559-5	5.25 (133.3)	4.50 (114.3)	3.00 (76.2)
C4559-6	6.00 (152.4)	5.25 (133.3)	3.75 (95.2)
C4559-7	6.75 (171.4)	6.00 (152.4)	4.50 (114.3)
C4559-8	7.50 (190.5)	6.75 (171.4)	5.25 (133.3)
C4559-9	8.25 (209.5)	7.50 (190.5)	6.00 (152.4)
C4559-10	9.00 (228.6)	8.25 (209.5)	6.75 (171.4)
C4559-11	9.75 (247.6)	9.00 (228.6)	7.50 (190.5)
C4559-12	10.50 (266.7)	9.75 (247.6)	8.25 (209.5)
C4559-13	11.25 (285.7)	10.50 (266.7)	9.00 (228.6)
C4559-14	12.00 (308.4)	11.25 (285.7)	9.75 (247.6)
C4559-15	12.75 (323.8)	12.00 (308.4)	10.50 (266.7)
C4559-16	13.50 (342.9)	12.75 (323.8)	11.25 (285.7)

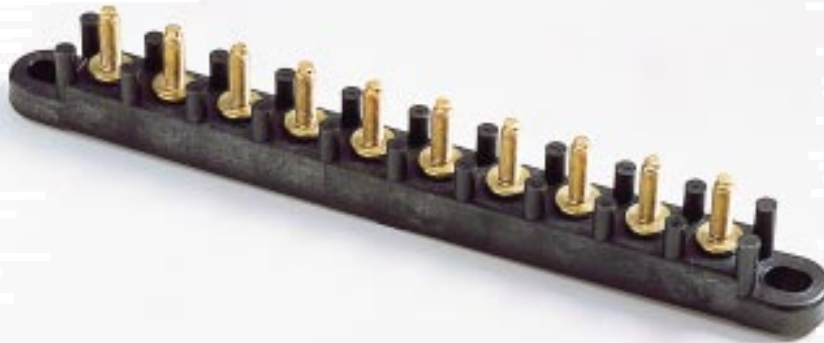

BIF document: 2072

Dimensions

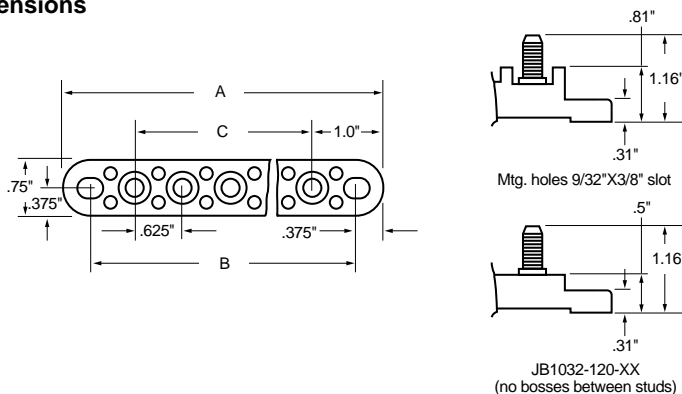

Dimensions in inches. Multiply by 25.4 for metric.

Series C5237

SPECIFICATIONS

Rating: UL: 30A, 300V; CSA: 30A, 600V.

Operating Temperature: 250°F (120°C)

Standards: 1 to 15 brass studs on .625" centers with #10-32 thread and a "dog point" to guide nut onto thread.

Torque: Recommended 20 in/lb (25 in/lb max.).

Marking: Numbers and arrows molded on top of barriers indicate terminals.

Approvals: UL E62622; CSA LR15364.

Part No.	A	B	C
C5237-1	2.00 (50.8)	1.25 (31.7)	-
C5237-2	2.62 (66.7)	1.87 (47.5)	1.25 (31.7)
C5237-3	3.25 (82.5)	2.50 (63.4)	1.87 (47.5)
C5237-4	3.87 (98.4)	3.12 (79.4)	2.50 (63.4)
C5237-5	4.50 (114.3)	3.75 (95.2)	3.12 (79.4)
C5237-6	5.12 (130.8)	4.37 (111.1)	3.75 (95.2)
C5237-7	5.75 (146.0)	5.00 (127.0)	4.37 (111.1)
C5237-8	6.37 (161.9)	5.62 (142.9)	5.00 (127.0)
C5237-9	7.00 (177.8)	6.25 (158.7)	5.62 (142.9)
C5237-10	7.62 (193.7)	6.87 (174.6)	6.25 (158.7)
C5237-11	8.25 (209.5)	7.50 (190.5)	6.87 (174.6)
C5237-12	8.87 (225.4)	8.12 (206.4)	7.50 (190.5)
C5237-13	9.50 (241.3)	8.75 (222.2)	8.12 (206.4)
C5237-14	10.12 (257.2)	9.37 (238.1)	8.75 (222.2)
C5237-15	10.75 (273.0)	10.00 (254.0)	9.37 (238.1)



		Ampere Rating	Dia.	Lgth.
	AGA	1, 1½, 2, 2½, 3, 5, 6, 7½, 10, 15, 20, 25, 30 BIF document: 2039	1/4"	5/8"
	AGC	1/2, 1, 1½, 2, 2½, 3, 4, 5, 6, 7½, 10, 15, 20, 25, 30, 35, 40 BIF document: 2001	1/4"	1¼"
	AGU	1, 2, 3, 4, 5, 10, 15, 20, 25, 30, 35, 40, 50, 60 BIF document: 2008	13/32"	1½"
	AGW	1, 1½, 2½, 3, 4, 5, 6, 7½, 15, 20, 30, 35 BIF document: 2040	1/4"	7/8"
	AGX	2, 2½, 3, 20, 25, 30 BIF document: 2041	1/4"	1"
	AGY	50 BIF document: 2073	1/4"	17/16"
	GBC	1, 2, 2½, 5, 8, 15, 16, 25, 30 BIF document: 2074	1/4"	31/32"
	GBF	GBF-25 BIF document: 2075	1/4"	21/32"
	MDL	1/2, 3/4, 1, 1½, 2, 2½, 3, 3 ² / ₁₀ , 4, 5, 6¼, 8, 10, 15, 20, 25, 30 BIF document: 2004	1/4"	1¼"
	SFE-4	SFE-4 BIF document: 2059	1/4"	5/8"
	SFE-6	SFE-6 BIF document: 2059	1/4"	7/8"
	SFE-7.5	SFE-7½ BIF document: 2059	1/4"	1"
	SFE-9	SFE-9 BIF document: 2059	1/4"	1"
	SFE-14	SFE-14 BIF document: 2059	1/4"	17/16"
	SFE-20	SFE-20 BIF document: 2059	1/4"	1¼"
	SFE-30	SFE-30 BIF document: 2059	1/4"	17/16"





SPECIFICATIONS

Small Dimension Fuse Panel

Accepts: 1/4" x 1-1/4" fuses. We recommend Buss® Series MDL/Time Delay; AGC/Non-Time Delay or GBB for Fast Acting fuse applications.

Poles: Standard panels with 1 to 12 poles.

Ratings: 300V.

Screw terminals: UL 30A, CSA 10A

Solder terminals: UL 25A, CSA 21A

.187" QC terminals: UL 15A, CSA 13A

.250" QC terminals: UL 20A, CSA 16A

Terminals: Solder, screw, .187" QC or .250" QC terminals, all tin plated.

Operating Temperature: -40°F (-40°C) to 175°F (80°C).

Material: UL rated 94VO thermoplastic.

Benefits: Patented design does not rely on fuse for solid, wobble-free mount. Subdivide multipole panels with simple finger pressure. Anti-pivot screw terminals prevent leads from twisting to the side when tightening. Insulating base seals periphery to reduce shorts to chassis from fuse clips.

Approvals: UL E14853A, Guide IZLT2 and CSA LR47235.

Dimensions

Multiple pole

Poles	A	B
1	.50 (12.7)	-
2	1.12 (28.6)	.62 (15.9)
3	1.75 (44.4)	1.25 (31.8)
4	2.37 (60.3)	1.87 (47.6)
5	3.00 (76.2)	2.50 (63.5)
6	3.62 (92.1)	3.12 (79.4)
7	4.25 (108.0)	3.75 (95.2)
8	4.87 (123.8)	4.37 (111.1)
9	5.50 (139.7)	5.00 (127.0)
10	6.12 (155.6)	5.62 (142.9)
11	6.75 (171.4)	6.25 (158.8)
12	7.37 (187.3)	6.87 (174.6)

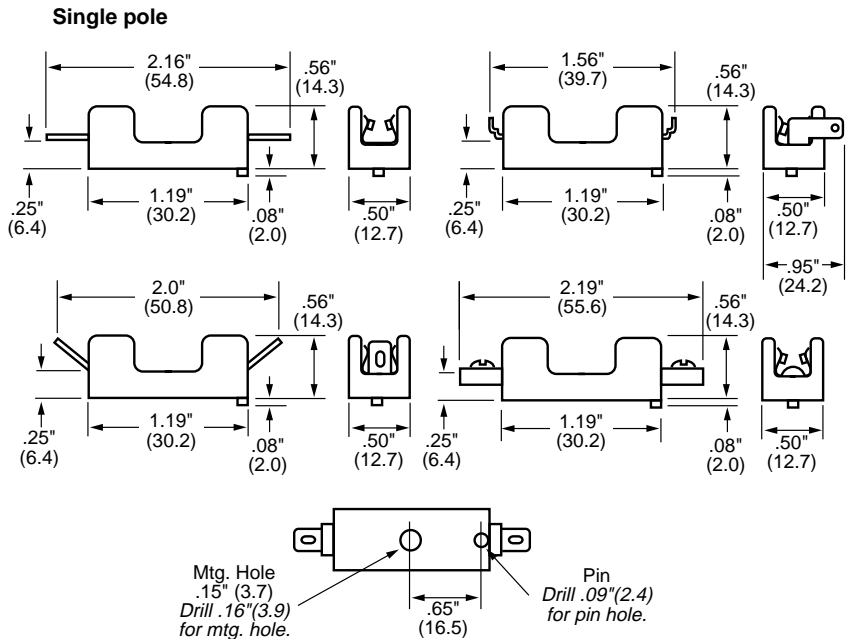

PART NUMBERING SYSTEM

Prefix	Series	Terminal	Terminal Angle	Poles	Options
BK - Bulk Pack*	S8	0 - Solder 1 - .187" QC 2 - .250" QC 3 - Screw	01 - Straight (0°) 02 - 40° 03 - Side**	01 to 12	X - Minus anti-rotation pin under base**

* Standard carton is 10 with total shelf package 100. Bulk Pack is 1,000 for single and 2 pole blocks; 200 for 3 to 8 pole blocks; 50 for 9 to 12 pole blocks.
 ** Available in single pole only.



Battery Disconnect Switch

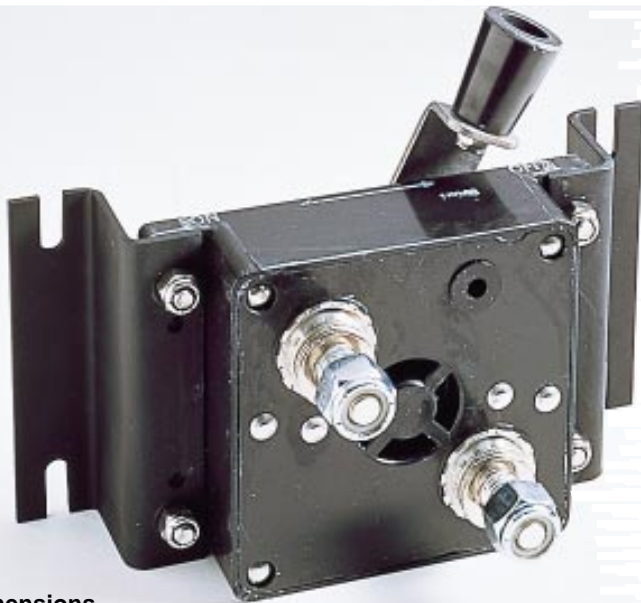

SPECIFICATIONS

Ratings: 50 VAC or VDC max; 400A continuous. Vehicle cranking and max. surge currents to 2000A (based on 20% duty cycle with ON times of 5 seconds max.).

Operating Temperature: 300°F (150°C) max.

Storage Temperature: -40°F (-40°C) to 150°F (65°C).

Applications: A non-fused current interrupt disconnect designed for opening the circuit between a battery and the complete electrical load of a battery powered system.

Options: Without mounting brackets — order Part No. 13969. For sealed version and other special options, consult factory.

Dimensions

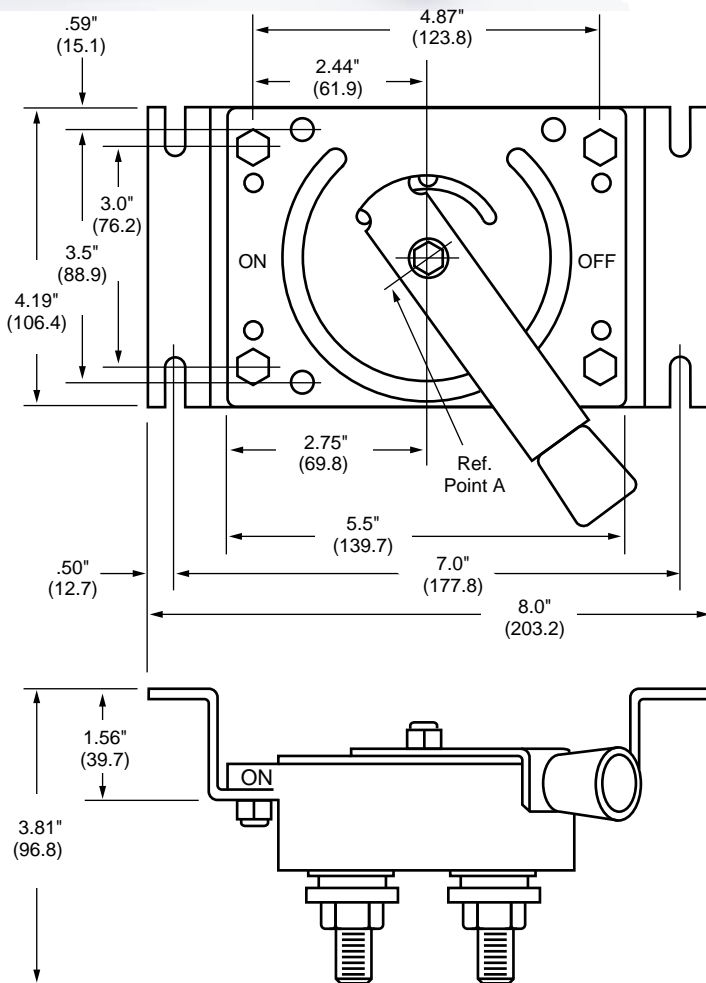

Handle Variations

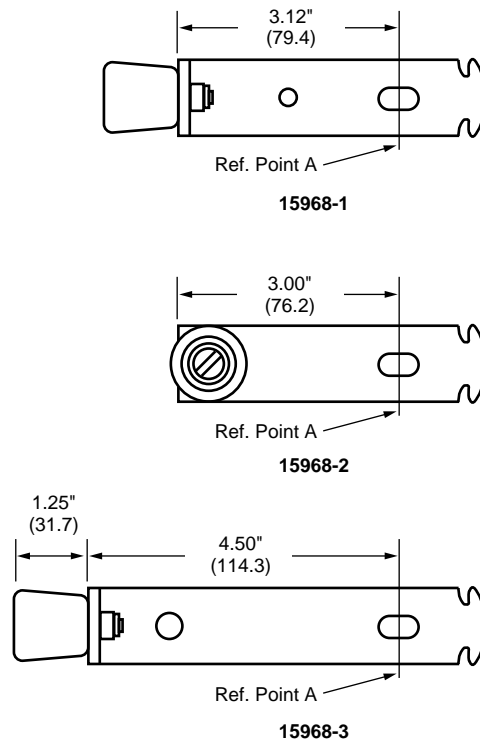

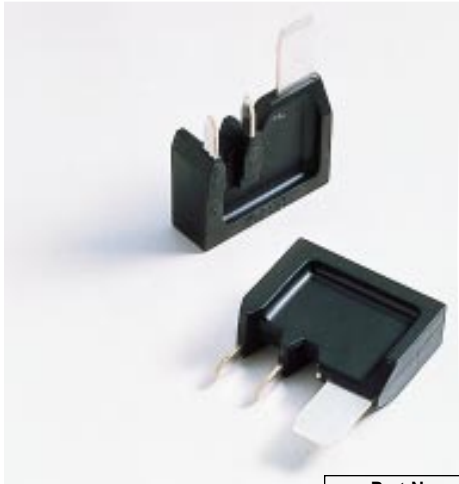

Part No.	Amp Rating
MXS-30	30
MXS-60	60

BIF document: 2077

MXS

Removable shunt, used to interconnect 8mm and 2 - 2.8 mm distribution buses.

Maximum current: 8 mm blade 60 Amps
2.8 mm blade 30 Amps each

Dimensions

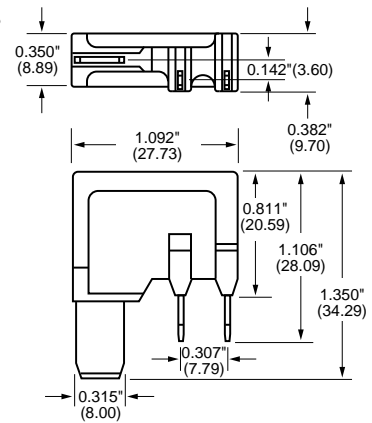

Dimensions

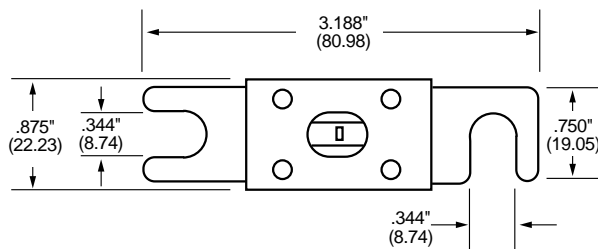

ANN

SPECIFICATIONS

Very Fast Acting

Physical Size: 22.2mm x 81.0mm

Voltage Rating: 125V AC

Approvals: UL Recognized, 35-400 Amps;
Guide JFHR2, File E56412

Catalog Symbol & Current Ratings:

125 Volts, IR2500A @ 125V

ANN-10	ANN-90	ANN-225	ANN-400
ANN-35	ANN-100	ANN-250	ANN-500
ANN-40	ANN-125	ANN-275	ANN-600
ANN-50	ANN-150	ANN-300	ANN-700
ANN-60	ANN-175	ANN-325	ANN-800
ANN-80	ANN-200	ANN-350	

BIF document: 2023

ANL

SPECIFICATIONS

Non-Time Delay

Voltage Rating: 32V AC

Approvals: UL Recognized 600, 675 and 750 Amps/32V;
Guide JFHR2, File E56412

Catalog Symbol & Current Ratings:

32 Volts,

IR 6000A			IR 2700A
ANL-35	ANL-125	ANL-250	ANL-500
ANL-40	ANL-130	ANL-275	ANL-600
ANL-50	ANL-150	ANL-300	ANL-675
ANL-60	ANL-175	ANL-325	ANL-750
ANL-80	ANL-200	ANL-300	—
ANL-100	ANL-225	ANL-400	—

BIF document: 2024



Circuit Protection Cross Reference Guide

This reference covers competitive part numbers of automotive circuit breakers, fuses and related accessories.

With the possibility of performance variations between Bussmann Products and those produced by other manufacturers, Bussmann recommends you verify all applicable specifications or request a sample before making a substitution. Contact your Bussmann representative for detailed information. Actual performance is dependent upon specific application parameters. Bussmann is unable to accept responsibility for any misapplication of Bussmann Products.

Bussmann	Competition	Bussmann	Competition
1AG	AGA	AGY	306
1AG	301	ANN	CNN
3AB	314	ANL	CNL
3ABSB	326	ATC	ATO
3AGSB	313	ATC	257
3AG (1/500 - 3 amp)	AGC (250 volt)	ATM	MIN
3AG (4 - 10 amp)	312 (250 volt)	ATM	297
3AG (4 - 30 amp)	AGC (32 volt)	CBS	812
3AG (4 - 30 amp)	311 (32 volt)	CBF	CBF
7AG	AGW	CBB	ACB
7AG	303	FLB	PAL
8AG	AGX	FLB	295
8AG	362	FLF	PAL
ABC	314	FLF	293
ABI	MID	FLM	PAL
AGA	301	FLM	294
AGC (.5 - 3 amp)	AGC	HHC	FHA 1
AGC (.5 - 3 amp)	312 (250 volt)	HHD	FHA 2
AGC (4 - 10 amp)	312 (250 volt)	HHL	FHM 1
AGC (4 - 35 amp)	AGC	HHM	FHM 2
AGC (4 - 35 amp)	311 (32 volt)	HHX	MAH 1
AGU (1 - 30 amp)	AGU	MAX	MAX
AGU (1 - 30 amp)	512	MAX	299
AGU (35 - 60 amp)	AGU	MEG	MEG
AGU (35 - 60 amp)	511	MEG	298
AGW	AGW	MDA	326
AGW	303	MDL	313
AGX	AGX	MDX	313
AGX	362	MSL	313
AGY	AGY	MTH	312

OEM Circuit Breakers

BUSSMANN	Control Devices, Inc.	Cole Hersee	FASCO	Mechanical Products	Potter & Brumfield	E-T-A	Weber	Heineman	TI/Klixon
PART NUMBER (SERIES)									
Series 120 SHORTSTOP®									
121 Auto Reset Version	PSA Series	30XXX Series	1711 Series/ 1731 Series						
122 Modified Reset Version		30XXX Series	1741 Series						
123 Manual Reset Version			1781 Series						
124 Auto Reset Version	PSA Series								
Series 174 FLAT-PAK				16XX Series	W58 Series	1658 Series	T11 Series	"HECTOR" Series	
Series 180 HI-AMP									
181 Auto Reset/ Panel Mount Version									CLA Series/ CDLA Series
184 Manual Reset/ Panel Mount Version									CLM Series/ CDLM Series
Series 190 MAXI™ Circuit Breakers									
191 Auto Reset Version	9000 Series								
192 Modified Reset Version	9100 Series								
Series 22 ATC® Circuit Breakers									
221	1771 Series								
222	2771 Series		EXT 200 Series						



Bussmann Automotive Technologies

Cooper Industries
Bussmann Division
P. O. Box 14460
St. Louis, Missouri 63178-4460, USA
Telephone: 314-394-2877
Fax: 800-544-2570

Bussmann Automotive Technologies
7300 W. Wilson Ave.
Chicago, IL 60656-4708
Telephone: 708-867-4600
Fax: 708-867-2211

EUROPE HEADQUARTERS
Cooper (UK) Ltd.
Bussmann Division
Burton-on-the-Wolds
Leicestershire LE12 5TH, U.K.
Telephone: 44-150-988-0737
Fax: 44-150-988-1309

BUSSMANN GERMANY
Frankfurter Landstrasse 19
64546 Mörfelden
Germany
Telephone: 49-61-057-6968
Fax: 49-61-067-4502

BUSSMANN FAR EAST
331 North Bridge Road
#03-02 Odeon Towers
Singapore 188720
Telephone: 65-336-3610
Fax: 65-336-4810

Bussmann®

Worldwide Circuit Protection Solutions